

UW Platteville

UW Fox Valley

Engineering



Student

Handbook

2007-08

UW-Platteville/UWFox Directory of Information

UWFox Staff

<u>Title/Area</u>	<u>Name</u>	<u>Office No.</u>	<u>Phone No.</u>
Program Manager	Jennifer Jensen	1837	832-2854
Student Services Coordinator	Cathleen Bronold	1837	832-2854
Faculty/Mechanical	Michael Zampaloni	1848	832-0104
Faculty/Mechanical	Tuba Bayraktar	1846	832-0103
Faculty/Electrical	Steven Popovich	1842	832-2647

UW-Platteville 800 Numbers

Admissions	800-362-5515
Alumni	800-897-2586
Continuing Education	888-281-9472
Distance Learning Center	800-362-5460
Enrollment Services	800-500-8914
Financial Aid	800-616-0412
Study Abroad	800-342-1725
Visitor Center	877-897-5288

Quick Reference Numbers

Bookstore (Caps & Gowns)	608-342-1486
Business Services	608-342-1226
Career Center	608-342-1183
Cashier's Office (Tuition/fees)	608-342-1211
Disability Services	608-342-1818
Registrar	608-342-1321
Textbook Center	608-342-1265

TABLE OF CONTENTS

	<u>Page</u>		<u>Page</u>
Adding/Dropping Courses.....	2	Parking Regulations.....	10
Advising.....	3	PeopleSoft.....	10
Careers/Job Placement.....	3	Professional Examination.....	11
Cooperative Education.....	4	Re-Entry to the University.....	14
Disability Services.....	6	Refund Policy.....	16
Financial Aid.....	7	Streaming Video Course Delivery.....	17
Grades.....	8	Student Organizations.....	11
Graduation.....	8	Summer Session.....	11
ME Curriculum Flow Chart.....	20	Textbooks.....	12
ME Program Sequences.....	18-19	Transcripts.....	14
ME Technical Electives Chart.....	21	Tuition/Fees/Payment.....	15
Non-Smoking Policy.....	10	Withdrawal from the University.....	14



ADDING/DROPPING COURSES

During regular Fall and Spring semesters, students may add or drop a course online as follows:

- ADD through the 5th day of classes
- DROP through the 10th day of classes. Students who drop a course after the tenth instructional day of the term through the end of the eighth week of that term will be charged a drop fee.
 - ✓ A \$10 fee will be charged for dropping each one credit class.
 - ✓ A \$15 fee will be charged for dropping each two or more credits class.
 - ✓ Students must pay the drop fees before the course is actually dropped.

If a student registered in a course drops or withdraws from that course in the first two weeks of class in that semester, that course shall not appear on the student's grade printout for that semester and hence will not be recorded on the student's transcript.

If a student registered in a course drops or withdraws from that course any time after the second week of classes, but prior to the end of the eighth week of classes, a notation of "Withdrawn" will appear on the student's grade printout and hence on the transcript.

Note: If a student drops all courses for which he or she is enrolled, then a Withdrawal Form must be completed and submitted to the FV Program Manager. See Withdrawal From the University.





ADVISING

Students who are enrolled in both UW-Fox Valley and UW-Platteville courses will continue to see the Fox Valley Program Manager each semester before registration. Appointment times will be posted on the door of the Program Office. Students should sign up for an appointment time, print and bring unofficial transcripts, plus a degree checklist to that appointment. Students who are no longer enrolled in UWFox courses will be assigned a UWP faculty advisor. Registration instructions, which are sent out each semester, will indicate advisor assignments.

During the advising appointment, students will be given an advising pin number required to remove the advising hold on the student's record in Peoplesoft. It is the student's responsibility to register for courses.



CAREERS – JOB PLACEMENT

Information regarding job or co-op openings is posted on the Career Information bulletin board outside program offices. New openings for co-ops and internships will be sent to qualified students via email. Resume and interviewing preparation assistance is available by appointment with the Fox Valley Program Manager.

UWPioneer Career Network

For information on careers and job placement or internships and co-ops use the UW-Platteville Web site, called UWPioneer Career Network at:

www.uwplatt.edu/careercenter/CareerLink.html.

Students can also access this site through the UW-Platteville Homepage – simply type “Career Center” in the Search Box. This site is a web resume database program created with students in mind. It is a valuable tool to use to conduct your job search and look for internship/co-op and summer employment.

From this site one can access links to the following categories of information:

- How to register with the Platteville Career Network Center
- Employer directory and employment opportunities listed with the Career Center
- On-line resume referral
- Web resume books
- Internship listings
- Job search magazines
- Career Related Events



COOPERATIVE EDUCATION

What is Cooperative Education?

Cooperative Education is a plan of education which effectively combines classroom learning and on-the-job experience so that one kind of learning illustrates and develops the other. The program takes its name from the close cooperation between the academic institution and the employer, assuring that the work experience will contribute significantly to the student's overall growth and professional development. Concurrently, the participating company receives numerous benefits from creative and enthusiastic students and contact with the university.

What are the benefits for a student that registers for a Co-op Assignment?

- Practical application of classroom studies
- Confirmation of career choice
- Acquisition of specialized engineering skills
- Better understanding of how industry works
- Better understanding of how to work with people
- The salary earned will help finance the student's education
- Increased confidence in one's own abilities and judgment
- Starting salary upon graduation is usually higher than for those students that have not participated in the co-op program

What are the benefits for the employer of a co-op student?

- Opportunity to evaluate the potential for permanent employment based on performance rather than just an interview
- Favorable publicity on campus, affecting students outside the co-op programs as well
- Opportunity to address lower priority projects with lower cost employees
- Co-op students tend to progress faster, go further, and stay longer than employees who did not have co-op experience
- Training costs decrease because a substantial portion is done at co-op salary rather than permanent salary

How the program works – the student perspective

Students who have completed the sophomore year with a GPA of 2.5 or higher are eligible for the program. Students who do not meet these requirements and believe that there are extenuating circumstances for their situation should meet with the UW-Platteville Program Manager at UW-Fox Valley. Any student interested in co-op positions should also meet with the Program Manager to discuss opportunities and application procedures.

How the program works – the employer perspective

Employers should provide a job description and any requirements the co-op student must meet. Interviews may be done on-campus, by phone, or on-site. Terms of employment (time period, salary, fringe benefits, transportation, etc.) are negotiated directly between the employer and the student. There is no obligation to hire the student for another work period or as a permanent employee.

Are students guaranteed a co-op assignment?

The number and types of positions offered vary each semester depending on the needs of companies involved in the co-op program. There is no guarantee that every student interested in co-op in a given semester will be placed in a position.

Will co-op participants extend their graduation date?

Students enrolled in the program generally add extended time to their degree completion date. However, the work experience enhances classroom learning, and the experience plus salary gained outweigh the extension of undergraduate studies.

Will students receive a salary?

Many employers provide some benefits or scholarships. Wages offered are based on many factors, including the engineering major, academic skills of the student, market demand, and geographic area.

What do students say about the experience?

Co-op participants indicate that combining their classroom exercises with actual engineering situations are an excellent way to learn more about the real-world working environment. The co-op experience also assists with college finances and postgraduate employment prospects.

What do employers of co-op students have to say?

Employers indicate that the program has mutual benefits to the employer and the student. Employers are able to train prospective employees in the practicalities of engineering and expose students to the rules, procedures, reports and ways of doing things that meet accepted industry standards. Company professionals profit from the knowledge of the student and often can keep better up-to-date on what is being taught in the classroom.





DISABILITY SERVICES

To Qualify for Services

A student with a disability must provide for UWP Services for Students with Disabilities Office current, relevant and comprehensive documentation from a qualifying professional of a physical or mental impairment that substantially limits one or more major life activities.

How to Obtain Services

- Contact the Fox Valley Program Manager with current documentation that indicates qualification for disability services.
- This documentation will be sent to UWP to determine that it satisfies disability verification guidelines and/or if further documentation is needed.
- UWP will determine reasonable accommodations and will complete a VISA (Verified Individualized Services and Accommodations) form. The student will then be instructed about procedures to obtain the reasonable accommodations.
- If learning aids are needed, such as books on tape or sign language assistance, requests need to be submitted 8 weeks prior to the start of classes. Requests should be directed to the FV Program Manager. The student should be aware that late requests may result in delay of accommodations.
- The student may also need to contact the Services for Students with Disabilities Office at 608-342-1818 or set up an appointment on the Platteville campus.

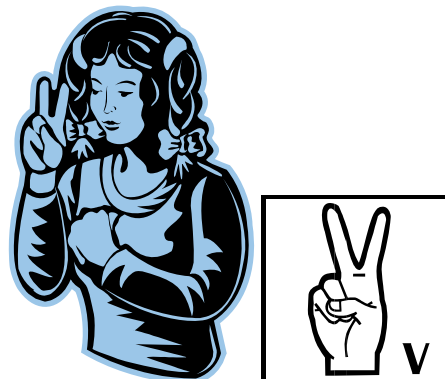



FINANCIAL AID

Instructions for UWP/UWColleges Consortium Agreements

Federal regulations prohibit you from receiving aid from more than one institution for the same period of attendance.

UWP/UWFox Collaborative Degree students who have been admitted to a UWP degree program and are continuing to take courses at UWFox may be eligible to receive financial aid through UWP. **In these cases, UWP is considered to be the “home institution” and, as such, the only campus at which the student can receive financial aid.** The UWFox campus is considered the “visiting institution.”

In order to be considered for aid from UWP a student must:

- Complete a FAFSA and release the information to UWP. The school code for UWP is 003921.
- Abide by UWP policies and procedures for financial aid purposes.
- Have a UWFox Student Services Administrator provide a completed Consortium Agreement for non-UWP courses. The Consortium Agreement should be returned to UWP Financial Aid Office.
- Have the UWP/UWFox Engineering Program Manager complete a Consortium Approval Form and send a copy to UWP Financial Aid Office.

UWP must verify the student’s enrollment in UWFox courses with the UWP/UWFox Engineering Program Manager. UWP will only count credits that have been previously approved by the UWP/UWFox Program Manager.

- All financial aid recipients must be meeting the Academic Progress Standards as set by UW-Platteville.
- Audit credits DO NOT count toward financial aid.
- Correspondence course credits DO NOT apply toward financial aid.
- Any changes in the student’s enrollment at the visiting institution must be reported to the UWP/UWFox Program Manager who will report such changes to UWP Financial Aid Office.
- For additional information regarding the UWP/UWFox Collaborative Engineering Program, please contact the FV Program Manager.

The COLLABORATIVE DEGREE PROGRAM CONSORTIUM APPROVAL FORM is available from the UWP/UWFox Program Manager.



GRADES

UW-Platteville determines the grade point average (GPA) by dividing the total number of grade points earned by the total number of credits attempted. The cumulative grade point average does not include credits and grade points earned at other colleges or universities (i.e. UWFox). When students repeat courses, only the most recent grade is counted in figuring the grade point average.

At the midpoint of each semester the faculty reports to the registrar all students doing unsatisfactory (“D” or “F”) work. Students with low grades receive low-grade reports. Students receiving reports are urged to meet with the faculty member(s) involved and their advisors immediately thereafter. At the end of each semester, grade reports are mailed to students at their permanent addresses. Grades may also be checked on PeopleSoft through the Self Service selection.

Sometimes it is appropriate, because of student illness or other unusual circumstances, to give a grade of Incomplete (I). After a student receives an Incomplete (I), it is the student’s responsibility to complete all work and assignments necessary to complete the class requirements prior to the ninth week of the ensuing semester. Unless a grade of Incomplete is changed to some other grade before the end of the ninth week of the ensuing semester, the Incomplete is changed to an “F.”

Grading mistakes should be rectified before the end of the ninth week of the ensuing semester. It is the student’s responsibility to call the instructor’s attention to any error in grading as soon as possible after grades are reported. It is the instructor’s responsibility to correct grading errors.



GRADUATION

Students enrolled in ME 4930 Senior Design Project should:

1. Complete an “Intent to Graduate” form, and file it with the UWP/UWFox Program Manager. The form is available at http://www.uwplatt.edu/registrar/files/graduate_form.pdf
2. Review with their advisor(s) all course work, credits earned, and possible waivers or changes to their degree.
3. Inform the UWP/FV Program Manager of any degree changes, substitutions, or waivers.
4. Prepare for Commencement (attendance is strongly encouraged) by ordering a cap/gown (through the UWP Bookstore) and arranging personal and other details.

The Registrar's Office will produce a final evaluation of a student's credits when the "Candidate for Graduation" card is submitted. This evaluation will formally review all credits taken, transferred or substituted/waived, and detail which course work remains or has not yet been taken. From this evaluation, students will recognize which credits or courses are to be completed in their last term of attendance. Cautious advising is very important during the senior year.

Students in their last semester of classes will receive a packet of information from the UWP Registrar's Office regarding graduation and commencement, including ordering of caps and gowns.

Commencements are held twice each year - at the end of the fall and spring semesters. All course work (including co-ops, internships, and student teaching) must be completed before a degree will be awarded and attendance at a Commencement ceremony is permitted.

Although attendance is optional, we strongly encourage all graduates and their families to attend this important ceremony and celebrate the achievements of new graduates.

See the following link for further information:

www.uwplatt.edu/registrar/graduation.html



NON-SMOKING POLICY

UWP students attending classes on the UW-Fox Valley campus, need to be aware and cooperative with the non-smoking policy on campus.

Smoking is prohibited within buildings at the University of Wisconsin-Fox Valley. State law requires that a smoking policy governs all public buildings and violation of a posted policy is subject to a forfeiture of not more than \$500.

Smoking is restricted outside campus buildings to areas specifically designated where it is permissible. The following areas are designated and signed as permissible:

- Campus parking lots (but not sidewalks).
- Exterior walkway on the East end of the 1300 wing.
- Exterior entrance between the 1300 wing and Student Union.
- Exterior entrance on the East side of the 1500 wing.
- Exterior courtyard between the Student Union and 1000 (science) wing.

All other entrances are designated and signed as Non-Smoking areas, including the walkways leading to the building, beginning at the curb.

Policies are subject to change



PARKING REGULATIONS

Parking on the UWFox campus is provided at no cost. Student parking is provided only in the lots west of the academic building. Parking is NOT permitted north or east of the academic building. Parking is allowed only in designated spaces.

HOWEVER, A PARKING PERMIT IS REQUIRED if parking in the campus lots between the hours of 8 AM and 4 PM. If that is the case, student's can pick up free parking stickers at the UWFox Business Services Office. Cars parked in the lots between the hours of 8 AM and 4 PM without a parking permit will be ticketed, resulting in fines. Non-payment of fines will cause a HOLD to be placed on all student records, including grades and transcripts.

Please visit Business Services for a copy of the complete Parking Policy and a free parking permit.

PEOPLESOFT (UWP Online Registration/Records System)

Students will get a log-in and temporary password from the FV Program Manager when they are admitted to UWP. Students must re-set the password the first time they log on to Peoplesoft. This password will expire in 90 days. **Students will NOT receive a warning of the expiring password, so need to keep track and re-set the password close to the end of the 90-day period.** If a student's password expires, he or she needs to contact the FV Program Manager, who will request that it be reset.

PROFESSIONAL EXAMINATION

Students who are interested in pursuing a professional engineering license need to take the Fundamentals of Engineering (FE) exam. Students in their last 2 semesters are eligible to take the exam. It is offered twice a year, usually in April and October.

Registration for the exam must be completed in advance. Registration for the April exam takes place the previous January. Registration for the October exam takes place in July. Please ask engineering program faculty or the FV Program Manager for more information or see the following link:

http://www.cps.ca.gov/TakeATest/Wisc/WiscProfEngineer/howto_reg.asp

STUDENT ORGANIZATIONS:

UWP engineering students are eligible to participate in any and all student organizations on the main campus. In addition, there are student organizations on the Fox campus as well.

Mechanical Contractors Association of America (MCAA) has established a student chapter, which holds regular meetings throughout the school year. Tuba Bayraktar is the faculty advisor with MCAA.

Other organizations on the main campus include American Society of Mechanical Engineers (ASME) UWP Student Chapter, and Society of Women Engineers (SWE) UWP Student Chapter.



SUMMER SESSION

There are two course offerings each summer: GE 2930 Applications of Electrical Engineering and a technical elective (varies each year).

Registration for summer courses is completed through Peoplesoft for continuing students. Special students, students who have disrupted their enrollment at UWP or students new to UWP need to complete a summer application form. Applications can be obtained from the Program Office.

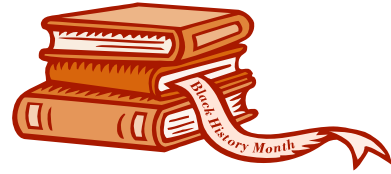

TEXTBOOKS

Textbook rental is included in the tuition and fees paid to UWP. Textbooks are distributed by the instructor at the first class meeting. Students who wish to pick up their textbooks early need to contact the UWP/FV Program Manager. When textbooks are distributed, there will be two forms included for the student to complete and return. Students should follow these steps:

1. **Read, fill-out, and sign** the forms entitled “Wisconsin Marital Property Act” and “UW Platteville Installment Credit Agreement.” Return both forms to your instructor.
2. **Review your personal information** printed at the top of the booklist. Please note any changes/corrections.
3. **Check all texts for damage.** If you notice any damage to the textbook, write it clearly on the bottom of the booklist. You must be specific about the damage and its location.
4. **Read** the Textbook Center Policies and Procedures (the opposite side of the booklist), **print** your name clearly at the top and **sign** at the bottom. Keep one copy of this for your records, and return the signed copy to your instructor.

Textbooks are to be returned to the instructor at the end of the semester, at either the last class meeting or at the final exam. The textbook return due dates are governed by the CLASS SCHEDULE published by the Registrar’s Office. Deadline for Spring and Fall sessions: Last day of published **Final Exams**. Summer session books are due the last class day. See the Textbook Center’s Policies & Procedures for information on damaged texts. Books handed back late will be subject to late fees.

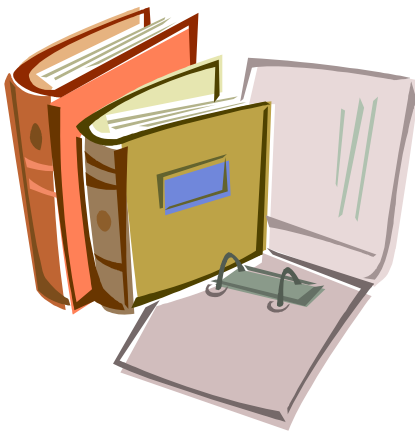

Textbook Purchase Information

If students are interested in purchasing their textbooks, they should contact the UWP Textbook Center. For textbook purchase information, please see “**Contact Us**” at <http://www.uwplatt.edu/~textbookctr> to e-mail the Textbook Center for pricing, etc.

Currently enrolled students may purchase active titles year-round, excluding the months of September and January, and **Finals Week in December**. Books sold during each semester are discounted. However, books kept past the applicable due date of each semester, or that are damaged upon return, are not discounted--amounts are due as billed.

Should a book come with a CD, the CD barcode must be listed in your email. The CD case must be returned by the end of the semester. The CD comes with the book, but not the CD case. In order to insure the CD's are returned with the books at the end of the semester, they are placed in CD cases [purchased from an outside vendor, not the publisher] and assigned an inventory barcode. Should you wish to keep the CD case, the cost is \$5. Quoted book sale prices do not include the CD case.



Make your check payable to: **UW-Platteville**

Check should be sent to: UW-Platteville
Textbook Center
1 University Plaza
Platteville, WI 53818-3099

Please list the barcode numbers of the books and any CD cases on your check in the comment section. Or, you can include a note with your check listing this information.

Upon receipt of your check, an itemized receipt (if requested by you) will be sent via e-mail showing author, title, and amount paid that can be given to your employer. If a receipt is requested, please advise your e-mail address.

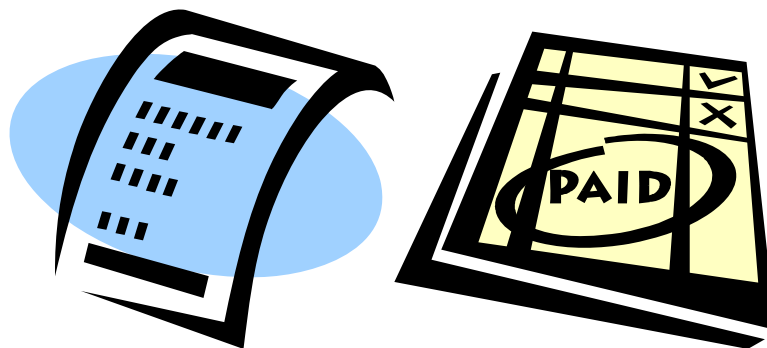



TRANSCRIPTS

Students need to request an official transcript be sent to UWP at the end of each Spring semester from any other college (UW-Fox Valley, UW-Oshkosh, etc.) where they have been enrolled during the past academic year.

Transcripts can be requested in person or in writing at the UWFox Business Office or the Registrar's Office of any other campus.

WITHDRAWAL FROM THE UNIVERSITY

To be official, any withdrawal from the university must be cleared with the UWP Registrar's Office, the student's academic advisor, Financial Aid Office, Textbook Center, and the Cashier's Office. Please see the UWP/FV Program Manager to begin the withdrawal process.

All fees and assessments must be paid on all books returned to the library before an official "clearance to withdraw" can be given. If you are enrolled in courses through both UWFox and UWP, then you will need to complete withdrawal forms FOR BOTH schools. UWP Withdrawal forms are available in the Program Manager's office. UWFox withdrawal forms are available in Student Services.



RE-ENTRY

If you have not attended a UWP course for a full semester, then you must apply for re-entry before you can register for classes again. Re-entry applications can be obtained from the UWP/FV Program Manager.

If a student has taken courses anywhere else during the time not enrolled with UWP, the student needs to obtain official transcripts from that school to submit with the re-entry application.



TUITION/FEES - PAYMENT POLICY

UW-Platteville bills all students for each semester approximately two weeks prior to the beginning of the semester. Financial aid, scholarships and educational loans will not be reflected on the bill. The initial payment is due approximately five days after the beginning of each semester. To avoid finance charges, accounts must be paid in full by the due date on the initial bill.

Registered students who do not receive a bill should contact the UWP Cashier's Office. Failure to receive a bill will not excuse students from payment deadlines.

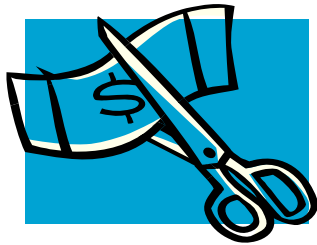

Partial Payment Plan

A partial payment plan is available for fall and spring semesters to students with a good credit history. (There is no partial payment plan available for summer school and winterim.) In order to qualify for the partial payment plan a copy of the Installment Credit Agreement form must be on file in the UWP Cashier's Office. A new Installment Credit Agreement form is required for each semester. Students with a demonstrated poor payment history may be denied access to the partial payment plan. The partial payment plan consists of an initial payment of 33 1/3% of all charges billed on the initial bill, due approximately five days after the beginning of each semester and two additional installments of 33 1/3% due approximately the fifth and ninth week of each semester. Exact due dates are provided with each initial billing statement. A finance charge of 1% per month on the unpaid balance (annual percentage rate of 12%) will be assessed on any balance remaining after the initial billing due date.

Payment in full of all tuition and fees prior to the initial billing due date will avoid finance charges. (This date is also provided with each initial billing statement.) Unpaid balances incur finance charges as detailed in the Installment Credit Agreement, a copy of which is included with the initial billing. Registration for future semesters will not be permitted unless the account balance is zero.

All checks should be made payable to UW-Platteville and should include the student's ID number. The payment must be in the UWP Cashier's Office on or before the due date to avoid service charges. UW-Platteville charges \$20.00 for all checks returned by the bank for insufficient funds (NSF).

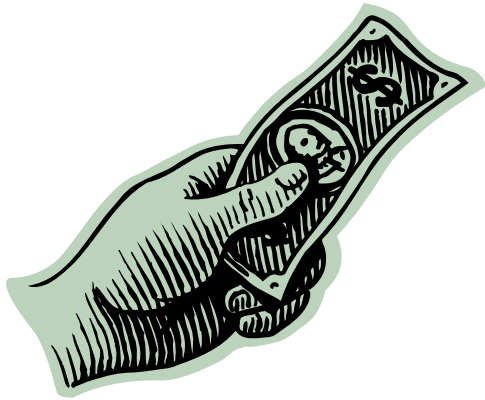

REFUND POLICY

Tuition and fees may be refunded upon official withdrawal from the university according to the current refund schedule, provided all official withdrawal forms are completed. The current refund schedule for regular fall and spring semesters are:

- 100 percent during the first two weeks of classes
- 50 percent during the third and fourth weeks of classes
- 0 percent thereafter

Refer to the UWP Cashier's Office Web page (see below) for the Summer refund schedule.

NOTE: If a student receives any type of federal financial aid (including Stafford loans and/or PLUS loans) and they withdraw from the university or reduce their credit load, their financial aid eligibility will be re-calculated and a percentage of **the aid may be considered unearned and may have to be returned to the funding source**. Please contact the UWP Financial Aid Office if you have any questions about this policy: 608-342-1836.



For any other billing questions visit the UWP Cashier's Office Website:
www.uwplatt.edu/business/cashiers/ or call 608-342-1211, or e-mail: cashieroff@uwplatt.edu.

Streaming Video Course Delivery

Some professional level courses may be offered via streaming video. Many of the electrical engineering courses will be offered this way. This format will supplement the mechanical engineering curriculum. For most of these courses, the instructor will be on the main campus with only electronic or phone contact with students. In some cases, the instructor will come to the Fox campus periodically to meet with students and/or facilitate lab experiments.

Streaming video allows a student to log into a course website (ie D2L) and view lectures from digital video files. From the UWP website, go to "Academic Tools". Then click on "Learn@UW Site". You will log in with your UW-Platteville user name and password. Once logged in, you should see a screen that identifies the semester and courses you are enrolled in that utilize streaming video.

University of Wisconsin-Platteville
Learn@UW Portal for Students & Faculty

No news.

Welcome Box	Search	News
Welcome Jenny!		No news.
My Settings: My Preferences My Profile	My Courses	
	Fall 2007	
	<input type="checkbox"/> Mechanical Engineering	
	MECHANISMS AND MACHINES	
	Summer 2007	
	<input type="checkbox"/> Electrical Engineering	
	LOGIC AND DIGITAL DESIGN	
My Admin Tools	SystemCheck	
Organization Related	Click here to do a system check!	
Manage Shared Files		
Manage Organization Files		
Course Related		
Manage Course		
Feedback		
Guides		

ME PROGRAM SEQUENCE

2 Classes/Semester

FALL YR 1

ME2630
Thermodynamics

SPRING YR 1

ME3040
Engineering Materials

MAT271
Differential Equations

FALL YR 2

ME3830
Mechanisms and Machines

ME3030
Dynamical Systems

SPRING YR 2

ME3300
Fluid Dynamics

ME3630
Applied Thermodynamics

SUM YR 2

GE2930
Apps. of Electrical Engr.

FALL YR 3

ME3330
Design of Machine Elements

ME3230
Manufacturing Processes

SPRING YR 3

ME3640
Heat Transfer

ME3730
Mechanical Systems Design

SUM YR 3

ME4XXX**
Technical Elective

FALL YR 4

ME4730
Thermo-Fluid Systems Design

ME3720
Mechanical Systems Lab

SPRING YR 4

ME4330
Automatic Controls

ME4720
Thermals Systems Lab

SUM YR 4

ME4XXX**
Technical Elective

FALL YR 5

ME4XXX**
Technical Elective

MAT240
Statistical Analysis

SPRING YR 5

ME4930
Senior Design Project

MAT262
Linear Algebra

* One math elective is required. Students can choose between MAT 262 and MAT 240.

** Three technical electives are required for graduation. One tech elective should be taken in a Summer Session in order to take the math elective during a regular semester.

NOTE: Taking the Technical Elective classes during Summer Sessions may reduce the total number of semesters to completion.

ME PROGRAM SEQUENCE

3 – 4 Classes/Semester

FALL YR 1

ME2630
Thermodynamics

ME3830
Mechanisms and Machines

ME3720
Mechanical Systems Lab

SPRING YR 1

ME3040
Engineering Materials

ME3630
Applied Thermodynamics

ME3640
Heat Transfer

MAT271
Differential Equations

SUM YR 1

GE2930
Apps. of Electrical Engr.

FALL YR 2

MECHNCHL 3330
Design of Machine Elements

ME3030
Dynamical Systems

ME3230
Manufacturing Processes

SPRING YR 2

ME3300
Fluid Dynamics

ME3730
Mechanical Systems Design

ME4330
Automatic Controls

ME4720
Thermal Systems Lab

SUMMER YR 2

ME4XXX**
Technical Elective

FALL YR 3

ME4730
Thermo-Fluid Systems Design

ME4XXX**
Technical Elective

SPRING YR 3

MECHNCHL 4930
Senior Design Project

MAT262
Linear Algebra

ME4XXX**
Technical Elective

* One math elective is required. Students can choose between MAT 262 and MAT 240.

** Three technical electives are required for graduation. One tech elective should be taken in a Summer Session in order to take the math elective during a regular semester.

NOTE: Taking the Technical Elective classes during Summer Sessions may reduce the total number of semesters to completion.

MECHANICAL ENGINEERING CURRICULUM

Required ME, GE, math, science and core courses

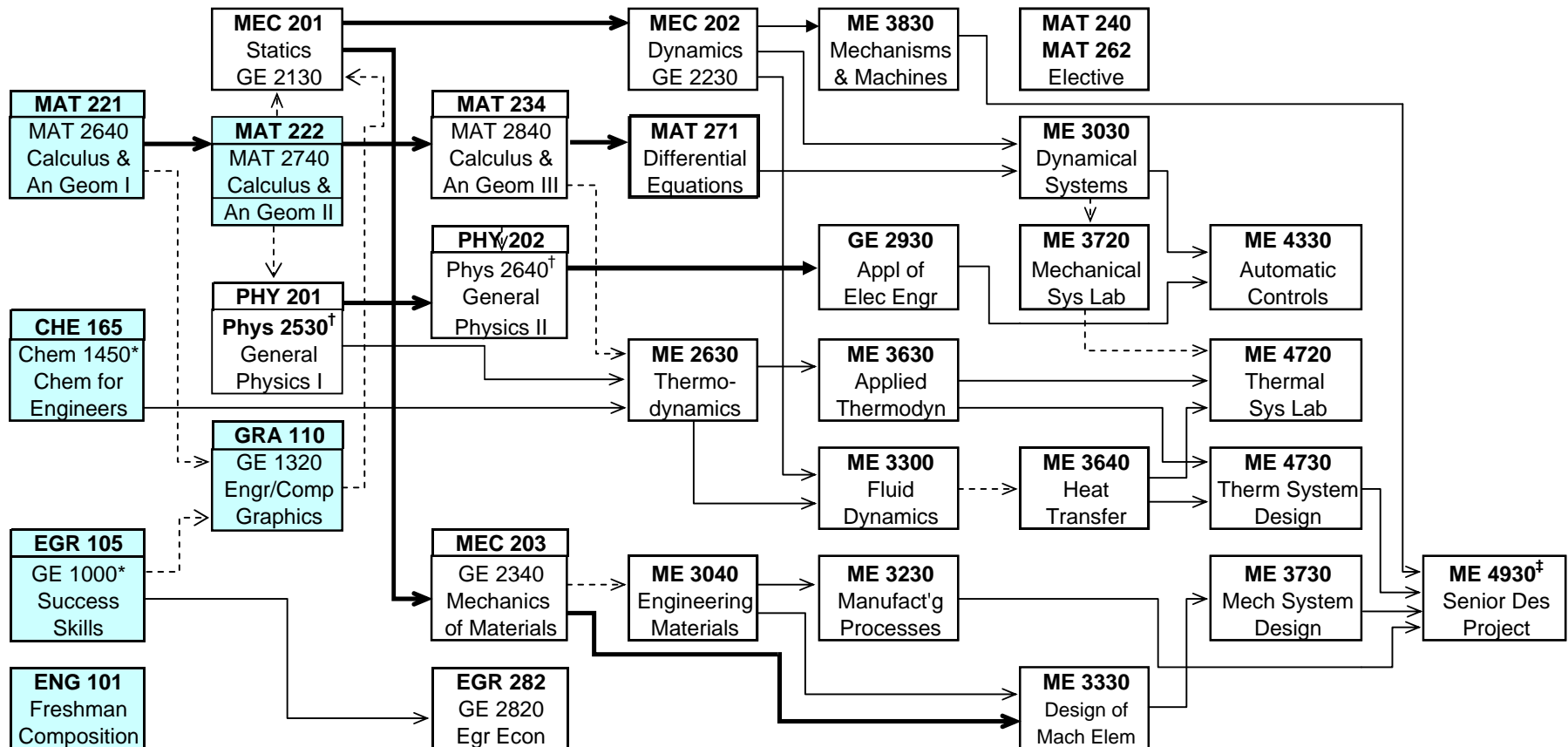

For general education requirements, see the current university catalog.

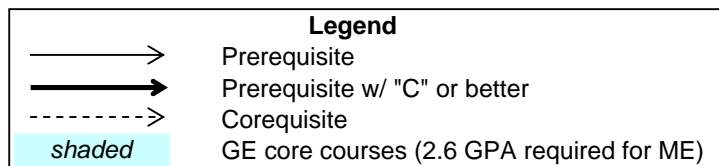

* Check current catalog for pre/corequisites

† Accompanying lab w/ separate course number

‡ Graduating seniors only

TECHNICAL ELECTIVES

All mechanical engineering students shall successfully complete 9 credit hours of Technical Electives

